

ESCABEAU ESCAMOTABLE 2 MARCHES CAILLEBOTIS

SPECIAL GRATING 2-STEP FOLDING STEP LADDER

REF. : **111 020**

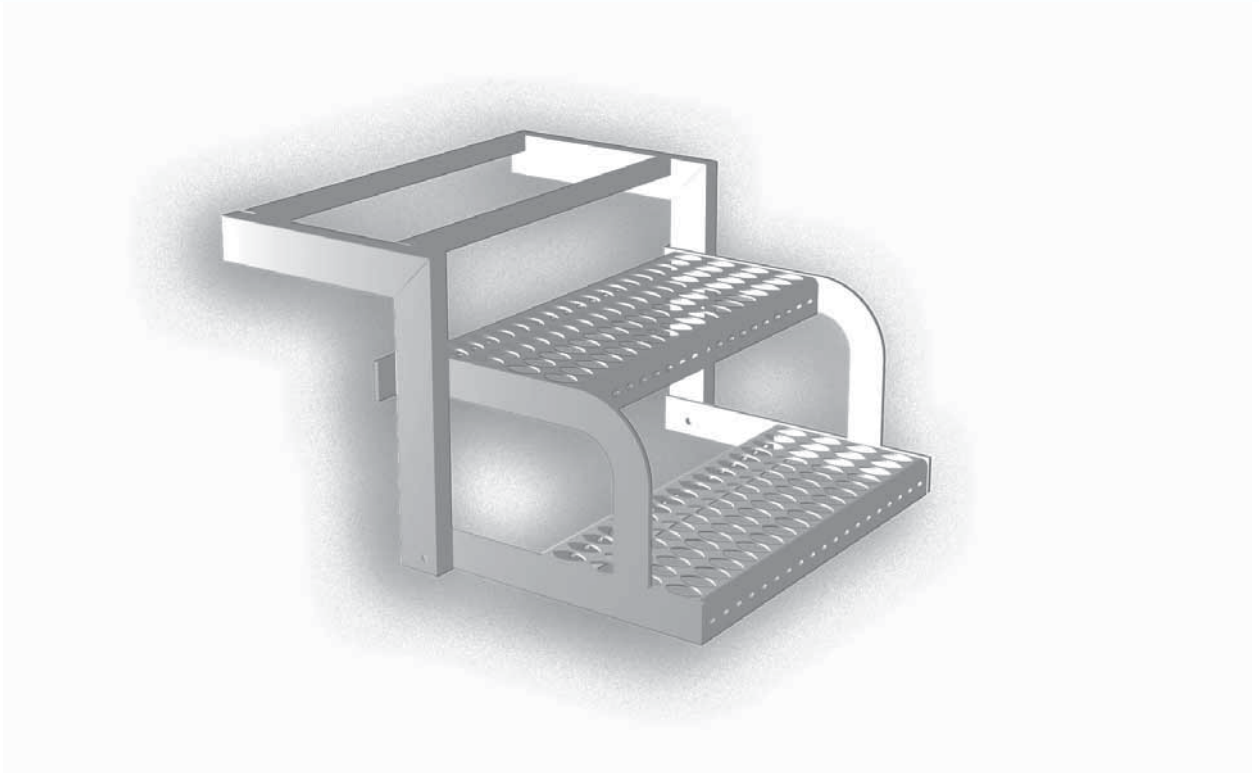

Matière/Material
Acier galvanisé
Galvanized steel

Caractéristiques/Characteristics
Largeur 624 mm
624 mm width

Poids/Weight
17 kg

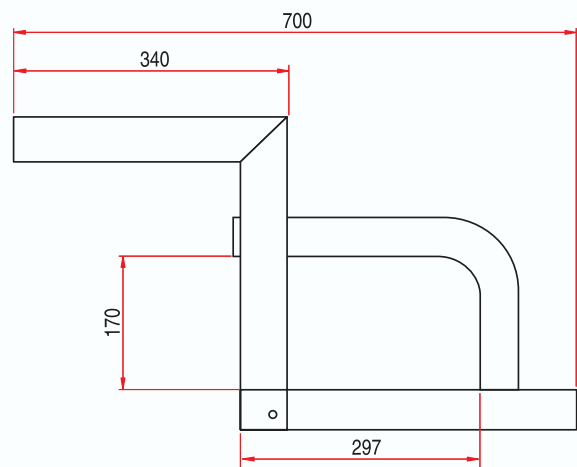
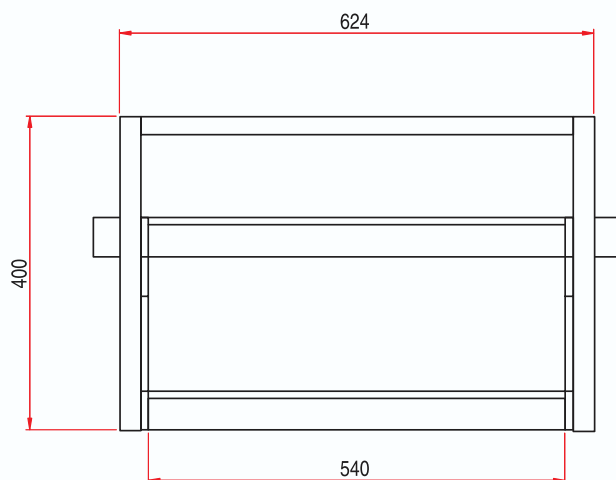

***Tous nos produits sont de marque et modèle déposés.**